

Star Tracker

Two Axis, High Precision Position Table Series BD/DC8800

Modes of Operation

- Absolute Positioning:
0.00001 deg. resolution
- Rate – absolute and relative,
excellent instantaneous rate
stability
- Tracking Mode – for real time
simulation of motion profiles
- Synthesized mode –
Sinusoidal motion, command
amplitude and frequency
- Local or remote control via
touch sensitive operator
panel or digital interface
- Analog readout and
command with 16 bit
resolution

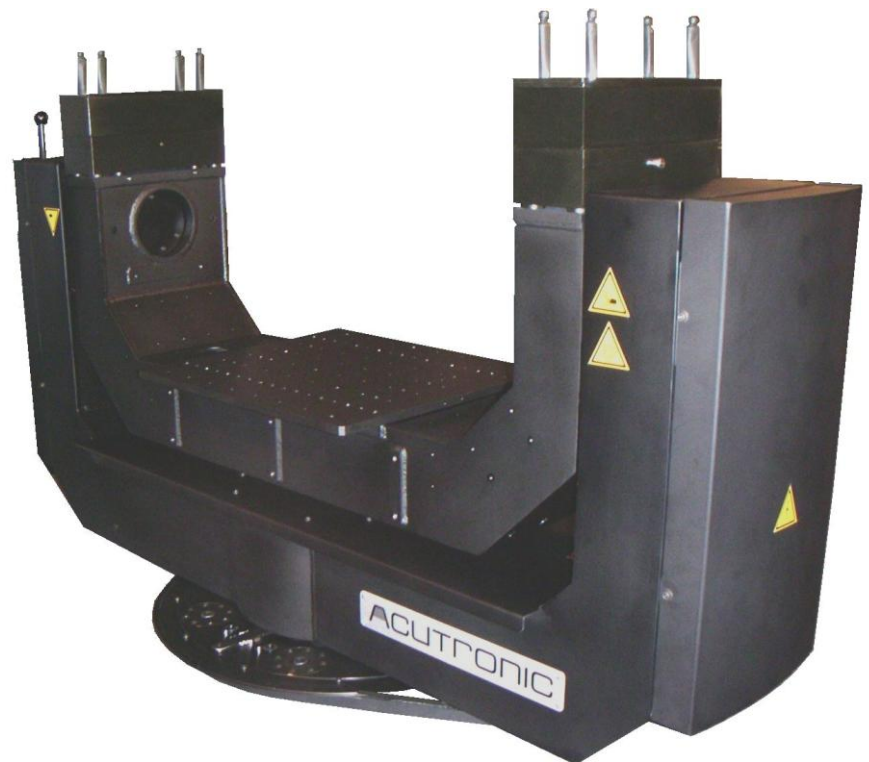

Description

The Series 8800 is designed to test satellite star tracking navigation platforms. The large offset of the table top keeps the optical sensors at the required axis intersection. The table is designed to be mounted on a surface plate together with the star simulator. Both axes of the table are supported by precision, angular contact bearings.

The system is configured with an inner, elevation axis and an outer, azimuth axis.

The inner axis table top has a threaded hole pattern for the mounting of the star tracker. Electrical and hydraulic access to the UUT is handled through twist cables and flexible couplings passing through the hollow axis shafts.

The installed DC torque motors have very low ripple torque and offer exceptionally smooth rate performance. Static balancing can be achieved by attaching suitable weights to the tines of the inner axis.

Construction materials are treated for long term dimensional stability. Protective coatings are used to prevent corrosion. Outer surfaces are black to avoid light reflections.

The digital controller ACUTROL[®]3000 controls the table. The controller has a touch sensitive display and a scalable analog input/output interface. Optionally, the standard digital interfaces of IEEE-488 and Ethernet (TCP/IP) can be supplemented with VMIC or SCRAMNet real time reflective memory interfaces.

| Unit Under Test | Unit | | |
|---------------------------------|---------|---------------------------|---------------------|
| Package size | mm | 400 x 400 x 400 | |
| Package Weight | Kg | nominal: 20; maximum: 30 | |
| Mechanical interface | mm | 410 x 410 table top | |
| Electrical interface | | twist cables in both axes | |
| Mechanical Performance | Unit | Inner Axis | Middle Axis |
| Angular Freedom | deg | +/-180 | +/-180 |
| Wobble | arc sec | < 2 _{peak} | < 2 _{peak} |
| Orthogonality | arc sec | +/- 2 | |
| Axis intersection | mm | < 0.5 sphere | |
| Mechanical Dimensions | Unit | | |
| Height of Axis intersection | mm | 580 | |
| Table Top offset | mm | 180 | |
| Maximum width across outer axis | mm | 1'390 | |
| Maximum Height | mm | 930 | |
| Static Performance | Unit | Inner Axis | Middle Axis |
| Position Accuracy | arc sec | ≤ 2 _{p-p} | ≤ 2 _{p-p} |
| Position Resolution (command) | arc sec | 0.036 | 0.036 |
| Pointing Accuracy | arc sec | ≤ 5.0 | ≤ 5.0 |
| Rate | deg/sec | 10 | 10 |

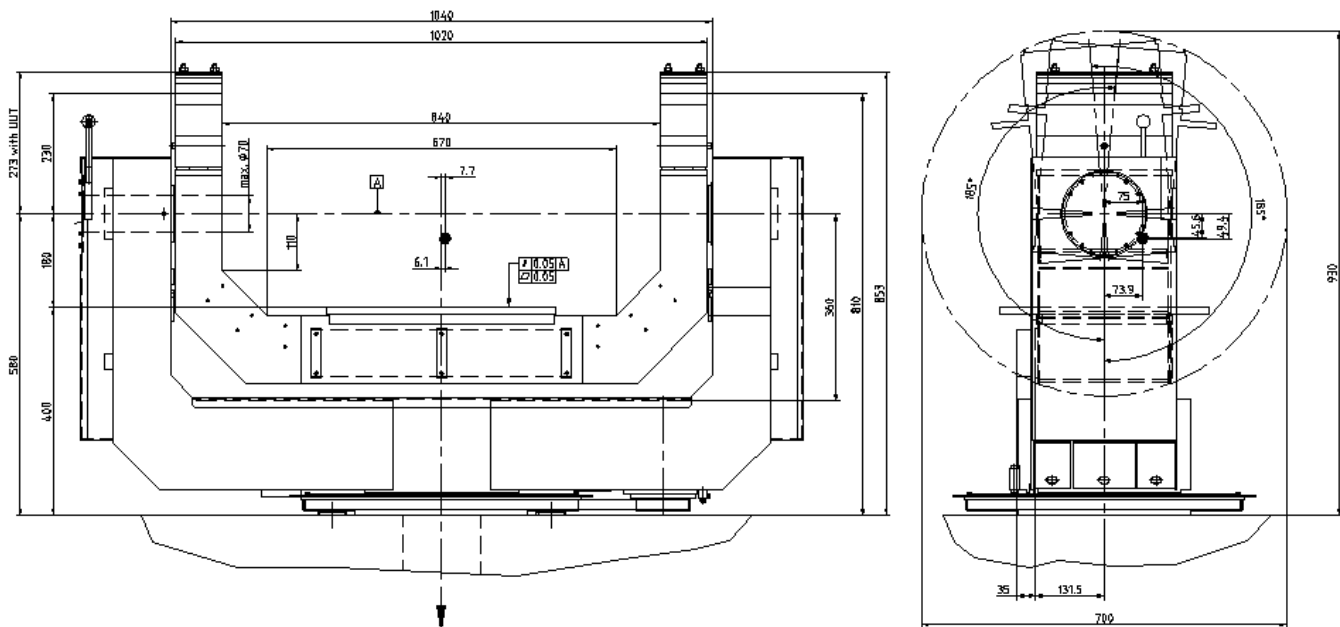

Options

- Torquers to meet extended rate and acceleration requirements
- Table top configurations
- Non standard slipping capsules
- Digital interfaces for real time control

For further information, contact:
 ACUTRONIC Switzerland Ltd
 Rosengartenstrasse 25
 8608 Bubikon, Switzerland
 marketing@acutronic.ch
 www.acutronic.com